



US 20190272789A1

(19) **United States**

(12) **Patent Application Publication**
PYON

(10) **Pub. No.: US 2019/0272789 A1**

(43) **Pub. Date: Sep. 5, 2019**

(54) **ORGANIC LIGHT-EMITTING DIODE (OLED) DISPLAY AND METHOD OF MANUFACTURING THE SAME**

G09G 3/3233 (2006.01)
H01L 51/56 (2006.01)
G09G 3/3266 (2006.01)

(71) Applicant: **SAMSUNG DISPLAY CO., LTD.**,
Yongin-si (KR)

(52) **U.S. Cl.**
CPC ... *G09G 3/3258* (2013.01); *G09G 2310/0264* (2013.01); *G09G 3/3291* (2013.01); *H01L 27/3276* (2013.01); *G09G 3/3233* (2013.01); *H01L 51/56* (2013.01); *H01L 27/3279* (2013.01); *H01L 27/3262* (2013.01); *G09G 3/3266* (2013.01); *H01L 27/3258* (2013.01); *H01L 27/3248* (2013.01); *H01L 51/5246* (2013.01); *G09G 2300/0842* (2013.01); *G09G 2300/0861* (2013.01); *G09G 2300/0819* (2013.01); *H01L 2227/323* (2013.01); *G09G 2300/043* (2013.01); *G09G 2300/0426* (2013.01); *H01L 51/5203* (2013.01)

(72) Inventor: **Chang-Soo PYON**, Yongin-si (KR)

(21) Appl. No.: **16/419,741**

(22) Filed: **May 22, 2019**

Related U.S. Application Data

(63) Continuation of application No. 15/285,275, filed on Oct. 4, 2016, which is a continuation of application No. 14/245,160, filed on Apr. 4, 2014, now Pat. No. 9,484,547.

Foreign Application Priority Data

(30) Oct. 30, 2013 (KR) 10-2013-0130452

Publication Classification

(51) **Int. Cl.**
G09G 3/3258 (2006.01)
H01L 51/52 (2006.01)
G09G 3/3291 (2006.01)
H01L 27/32 (2006.01)

(57) **ABSTRACT**

An organic light-emitting diode (OLED) display is disclosed. In one aspect, the OLED display includes a lower substrate including a display area and a non-display area surrounding the display area, wherein a plurality of pixels are formed in the display area. The OLED display also includes an embedded circuit formed in the configured to apply a plurality of signals to the pixels, and an initialization wiring formed in the non-display area and configured to apply an initialization voltage to each of the pixels. The initialization circuit is formed in a layer so as to at least partially overlap with the area of the embedded circuit.

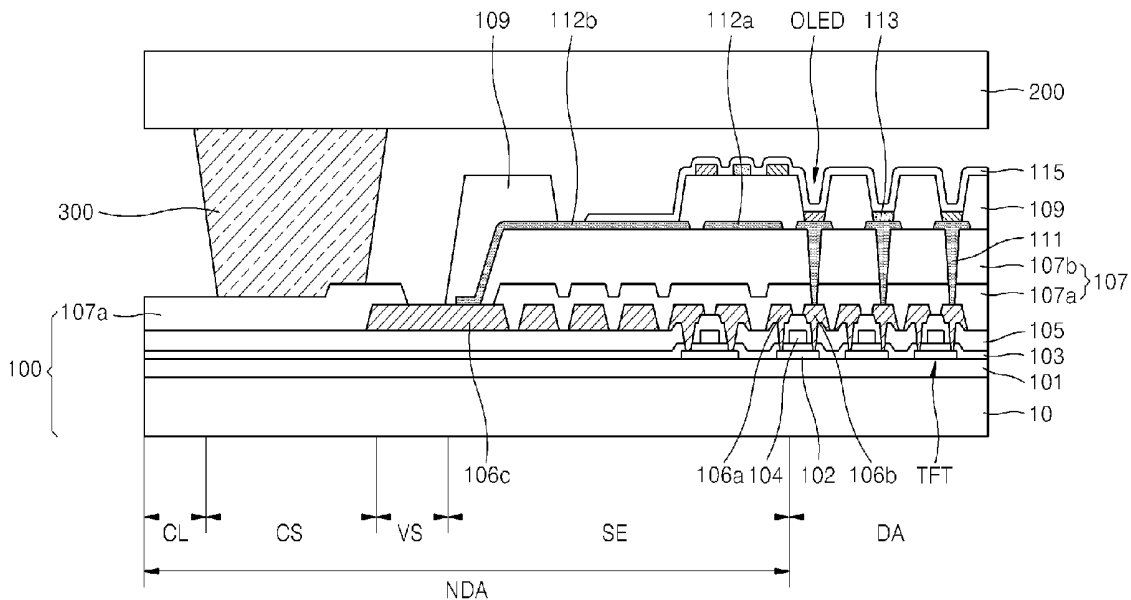

FIG. 1

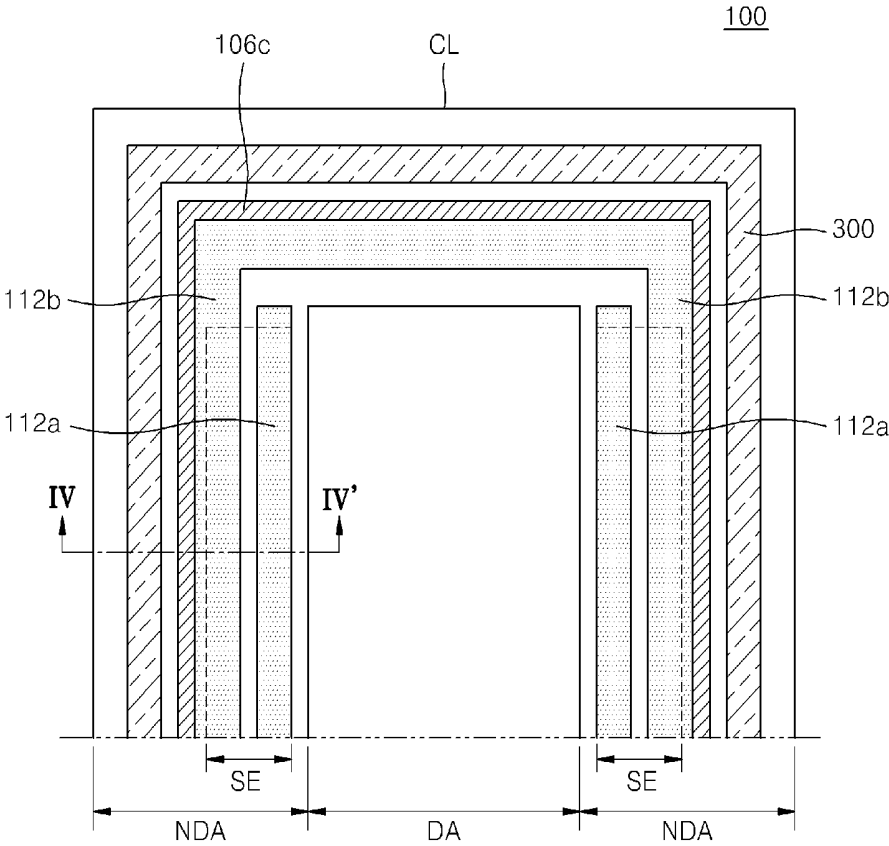

FIG. 2

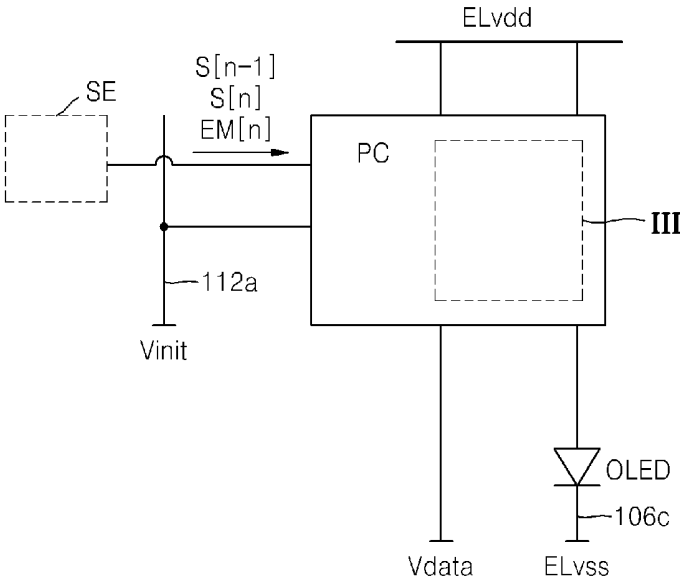

FIG. 3

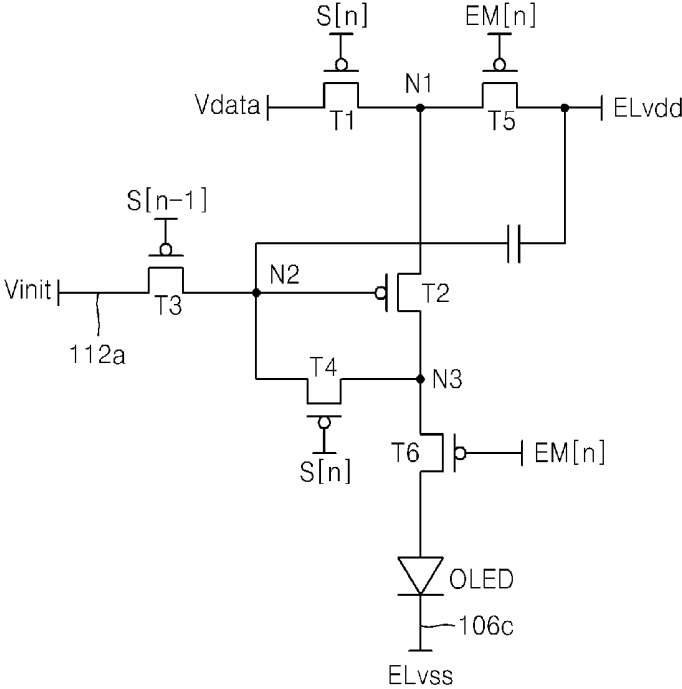

FIG. 5

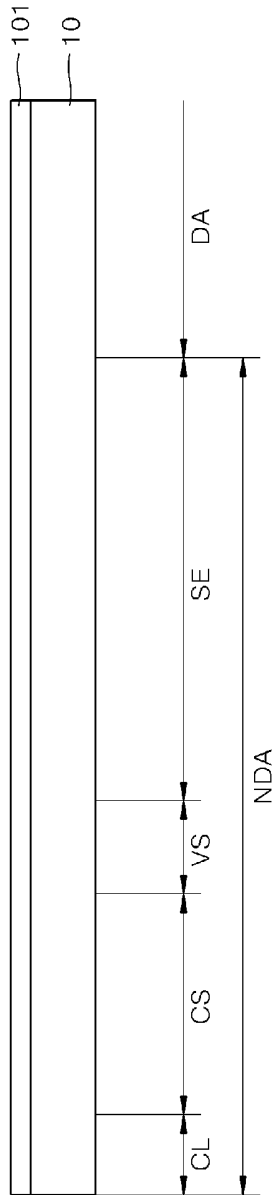

FIG. 6

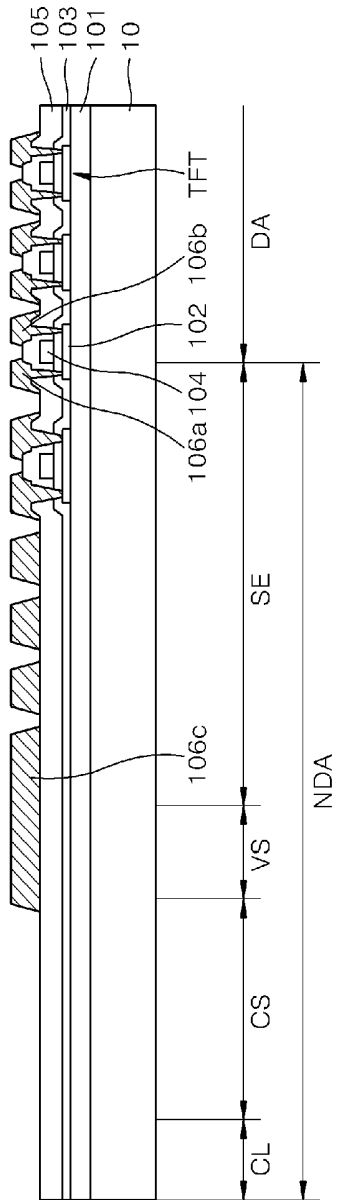

FIG. 7

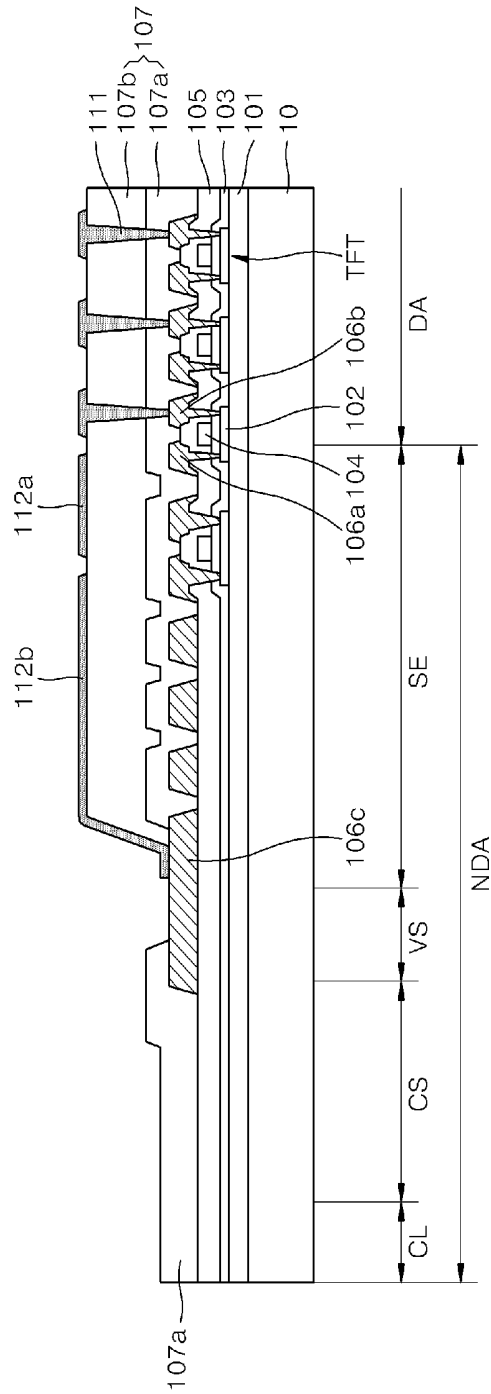

FIG. 8

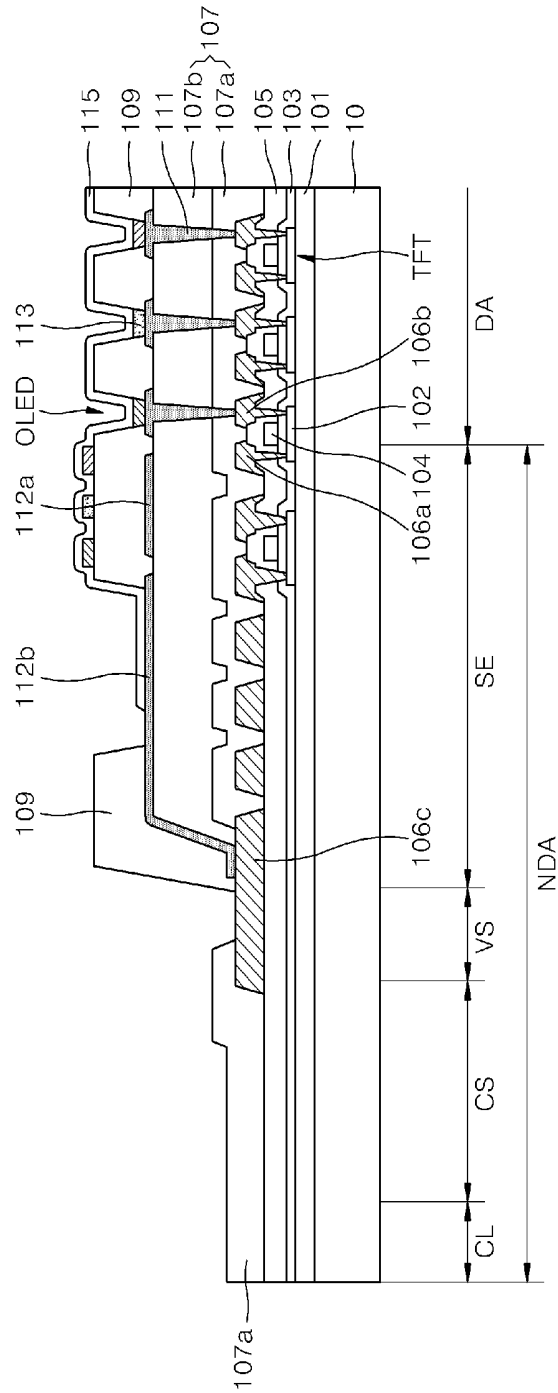

FIG. 10

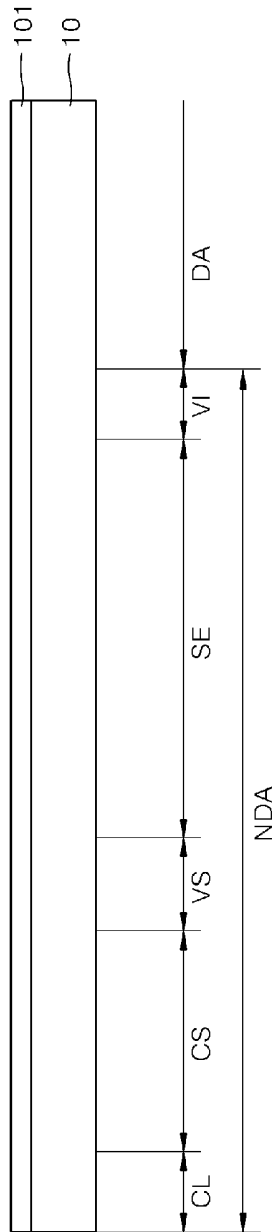

FIG. 11

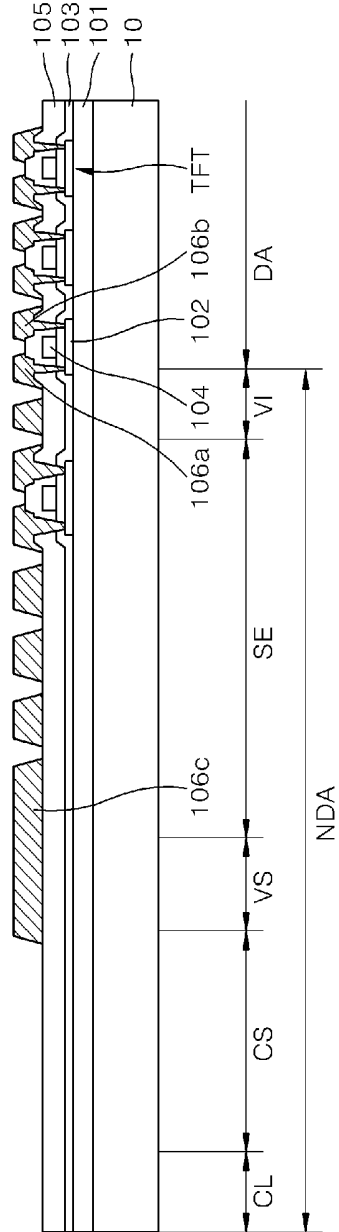

FIG. 12

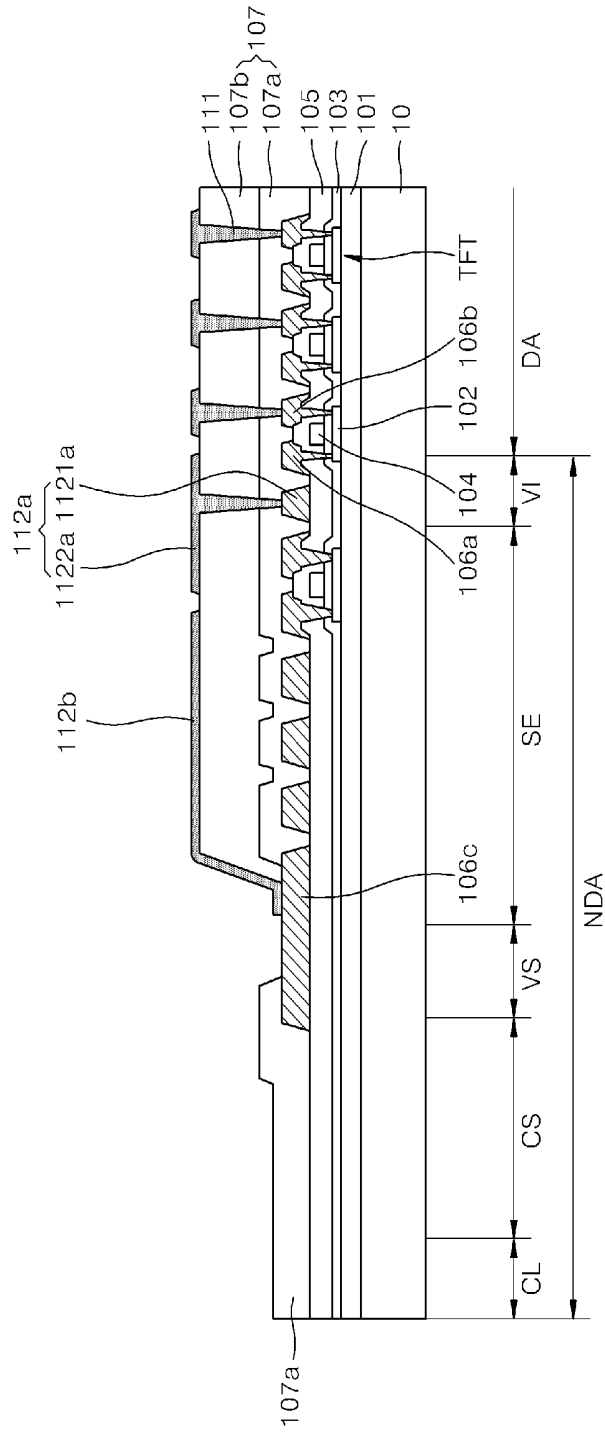

FIG. 13

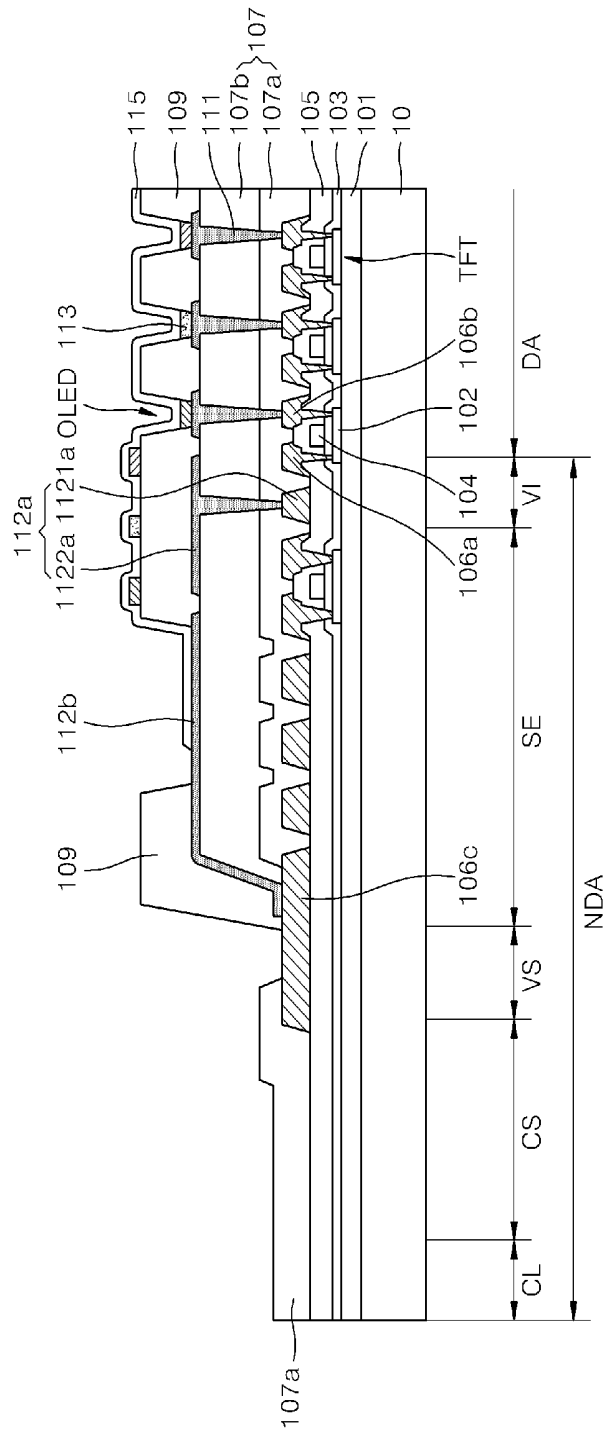
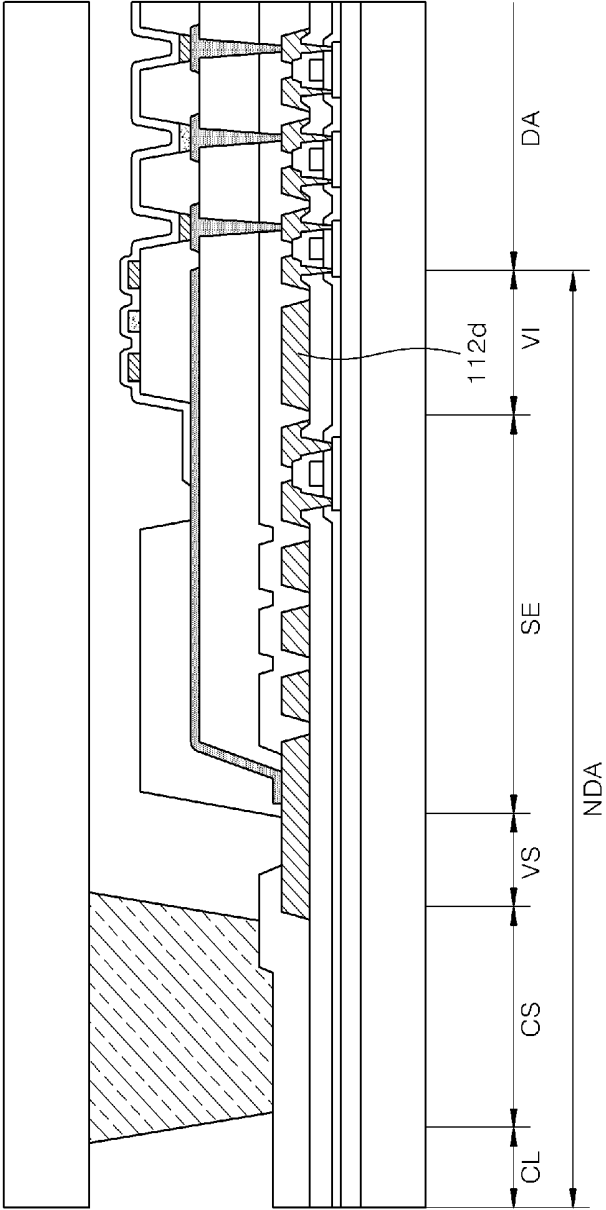

FIG. 14



**ORGANIC LIGHT-EMITTING DIODE
(OLED) DISPLAY AND METHOD OF
MANUFACTURING THE SAME**

CROSS-REFERENCE TO RELATED
APPLICATIONS

[0001] This application is a continuation of U.S. patent application Ser. No. 15/285,275, filed on Oct. 4, 2016, which is a continuation of U.S. patent application Ser. No. 14/245,160, filed on Apr. 4, 2014, now U.S. Pat. No. 9,484,547, which claims the benefit of Korean Patent Application No. 10-2013-0130452, filed on Oct. 30, 2013, in the Korean Intellectual Property Office, the disclosures of which are incorporated herein in their entirety by reference.

BACKGROUND

Field

[0002] The described technology generally relates to an organic light-emitting Diode (OLED) display and a method of manufacturing the same.

Description of the Related Technology

[0003] Organic light-emitting diode (OLED) displays are widely viewed as next generation displays due to their favorable characteristics such as fast response speeds, self light-emitting characteristics that provide wide viewing angles, and high brightness in comparison to liquid crystal displays (LCDs) that are now commercially available.

[0004] The substrate of an OLED display can be divided into a display area, in which an image is displayed, and a non-display area, which is classified as a dead space because images are not displayed therein. Recently, since consumers prefer large screens and narrow bezels, research into reducing such dead space has been actively conducted.

SUMMARY OF CERTAIN INVENTIVE
ASPECTS

[0005] One inventive aspect is an OLED display and a method of manufacturing the same.

[0006] Another aspect is an OLED display including a lower substrate that is divided into a display area displaying an image by including pixels and a non-display area around the display area, an embedded circuit unit that is included in the non-display area and includes circuits for applying signals to the display area, and an initialization wiring that is included in the non-display area, applies a voltage for initializing the pixels, and overlaps the embedded circuit unit.

[0007] The initialization wiring may completely overlap the embedded circuit unit.

[0008] The initialization wiring may be included in a same layer as pixel electrodes that are included in the pixels.

[0009] The initialization wiring may include a transparent conductive oxide material.

[0010] The OLED display may further include a seal that is included to surround outer edges of the non-display area and a power wiring that is included between the seal and the embedded circuit unit and applies power to the pixels.

[0011] A portion of the initialization wiring may overlap the embedded circuit unit.

[0012] The initialization wiring may be formed of multiple layers including a lower layer which is included in a same

layer as the power wiring and an upper layer which is connected to the lower layer by a contact structure and is included in a same layer as the pixel electrodes that are included in the pixels.

[0013] The lower layer may completely overlap the upper layer and the width of the lower layer in a width direction may be smaller than the width of the upper layer in a width direction.

[0014] The upper layer may include a transparent conductive oxide material and the lower layer may include a metallic material.

[0015] The embedded circuit unit and the initialization wiring may be symmetrically disposed at both edges of the display area which are opposite to each other.

[0016] The embedded circuit unit may include at least one or more of a scan driver and an emission driver.

[0017] Another aspect is a method of manufacturing an OLED display including providing a substrate that is divided into a display area displaying an image and a non-display area around the display area, forming pixel circuits in the display area on the substrate and forming an embedded circuit unit in the non-display area on the substrate, forming an insulating layer to cover the pixel circuits and the embedded circuit unit, forming pixel electrodes connected to the pixel circuits in the display area on the insulating layer and forming an initialization wiring overlapping the embedded circuit unit in the non-display area on the insulating layer, and forming organic emission layers on the pixel electrodes and forming a counter electrode on the organic emission layers.

[0018] The initialization wiring may be formed to completely overlap the embedded circuit unit and the pixel electrodes and the initialization wiring may include a transparent conductive oxide material.

[0019] The method may further include forming a seal to surround outer edges of the non-display area, wherein the forming of the embedded circuit unit may include forming a power wiring between the seal and the embedded circuit unit.

[0020] The initialization wiring may include a lower layer and an upper layer, the forming of the power wiring may include forming the lower layer, which is included in a same layer as the power wiring, between the embedded circuit unit and the display area, and the forming of the initialization wiring may include forming the upper layer which is connected to the lower layer by a contact structure and is included in a same layer as the pixel electrodes.

[0021] A portion of the upper layer may be formed to overlap the embedded circuit unit and the pixel electrodes and the upper layer may include a transparent conductive oxide material and the lower layer may include a metallic material.

[0022] Another aspect is an OLED display including a substrate including a display area and a non-display area, a plurality of pixels formed over the substrate in the display area, a pixel driver formed over the substrate in the non-display area adjacent to the display area and configured to apply a plurality of driving signals to the pixels, and an initialization wiring formed in a layer that at least partially overlaps with the area of the pixel driver and configured to apply an initialization signal to the pixels.

[0023] The initialization wiring includes upper and lower layers and the upper layer at least partially overlaps the pixel driver. The OLED display further includes an OLED elec-

trically connected to the pixels, wherein the initialization wiring is closer to the OLED than the pixel driver.

[0024] At least part of the initialization wiring is formed at a border of the display area and the non-display area. The initialization wiring is formed above the pixel driver.

BRIEF DESCRIPTION OF THE DRAWINGS

[0025] FIG. 1 is a plan view schematically illustrating a portion of an organic light-emitting diode (OLED) display according to an embodiment.

[0026] FIG. 2 is a circuit diagram illustrating connections between a pixel and wirings of FIG. 1.

[0027] FIG. 3 is a circuit diagram illustrating region "III" of FIG. 2 in more detail.

[0028] FIG. 4 is a cross-sectional view taken along line IV-IV' of FIG. 1.

[0029] FIGS. 5 to 8 are cross-sectional views sequentially illustrating a method of manufacturing the lower substrate of FIG. 4.

[0030] FIG. 9 is a cross-sectional view illustrating an OLED display according to another embodiment.

[0031] FIGS. 10 to 13 are cross-sectional views sequentially illustrating a method of manufacturing the OLED display of FIG. 9.

[0032] FIG. 14 is a cross-sectional view illustrating an OLED display according to a comparative example.

DETAILED DESCRIPTION OF CERTAIN INVENTIVE EMBODIMENTS

[0033] Reference will now be made in detail to embodiments, examples of which are illustrated in the accompanying drawings, wherein like reference numerals refer to like elements throughout. In this regard, the embodiments may have different forms and should not be construed as being limited to the descriptions set forth herein. Accordingly, the embodiments are merely described below, by referring to the figures, to explain aspects of the described technology.

[0034] While the described technology is amenable to various modifications and alternative forms, specific embodiments have been shown by way of example in the drawings and are described in detail below. Effects and features of the described technology, and implementation methods thereof will be clarified through following embodiments described with reference to the accompanying drawings. The described technology may, however, be embodied in different forms and should not be construed as limited to the embodiments set forth herein.

[0035] Hereinafter, embodiments will be described in detail with reference to the accompanying drawings. Like reference numerals in the drawings denote like elements, and thus their description will be omitted.

[0036] The expressions "width direction" and "longitudinal direction" may be used when wirings are described in the specification. Herein, the expression "width direction" refers to the direction perpendicularly crossing the direction in which the wiring extends and the expression "longitudinal direction" refers to the direction parallel to the direction in which the wiring extends.

[0037] As used herein, the term "and/or" includes any and all combinations of one or more of the associated listed items. Expressions such as "at least one of," when preceding a list of elements, modify the entire list of elements and do not modify the individual elements of the list.

[0038] FIG. 1 is a plan view schematically illustrating a portion of an organic light-emitting diode (OLED) display according to an embodiment.

[0039] The OLED display includes a lower substrate 100 including pixels, an upper substrate for sealing the lower substrate, and a seal for bonding the lower substrate and the upper substrate together. FIG. 1 is a plan view schematically illustrating the lower substrate 100 of the OLED display.

[0040] The lower substrate 100 is divided into a display area DA and a non-display area NDA around the display area DA.

[0041] The display area DA is an area in which pixels are disposed to display an image. Each pixel includes an OLED emitting light and a pixel circuit for driving the OLED. The pixel circuit may include a plurality of thin film transistors and at least one or more capacitors. A detailed description of the pixel circuit will be provided later with reference to FIGS. 2 and 3.

[0042] The non-display area NDA is a dead space in which an image is not displayed. A seal 300, a power wiring 106c, an embedded circuit unit or embedded circuit SE, and an initialization wiring 112a are formed in the non-display area NDA. Hereinafter, a portion of the non-display area NDA near the display area DA is referred to as an "inner" portion and a portion of the non-display area NDA far from the display area DA is referred to as an "outer" portion. Hereinafter, the configuration of the non-display area NDA will be described beginning from the outer to the inner non-display area NDA.

[0043] A cutting line CL is included in the outermost portion of the non-display area NDA that defines the outermost portion of the non-display area NDA. A plurality of lower substrates 100 are prepared in a mother substrate and then individually separated by cutting the mother substrate along the cutting line CL. The seal 300 is included inside of the cutting line CL.

[0044] The seal 300 may be included to surround outer edges of the non-display area NDA by a closed curve. The seal 300 seals the lower substrate 100 by bonding the lower substrate 100 and the upper substrate together in order to prevent the penetration of moisture or foreign matter into the lower substrate 100. The power wiring 106c is included inside of the seal 300.

[0045] The power wiring 106c is wiring that delivers power to a counter electrode of the pixels. For example, the counter electrode may be a cathode and the power wiring 106c may deliver a low potential voltage to the counter electrode. In order to prevent a voltage drop, the power wiring 106c may have a large width and may include a sufficiently large area that may be electrically connected to the counter electrode a short distance from the counter electrode. For example, the power wiring 106c may surround the periphery of the display area DA. The power wiring 106c is connected to the counter electrode through a connection unit or connection wiring 112b. The connection unit 112b acts as a contact that connects the power wiring 106c to the counter electrode which are included in different layers. The connection unit 112b may also overlap the embedded circuit unit SE to be described later. The connection unit 112b may be formed over a wide area in order to prevent a voltage drop and may surround the periphery of the display area DA similar to the power wiring 106c. The embedded circuit unit SE is included in the inside of the power wiring 016c.

[0046] The embedded circuit unit SE includes circuits for transmitting various signals to the pixels. The embedded circuit unit SE may include a plurality of thin film transistors and wirings. For example, the embedded circuit unit SE may include at least one or more of a scan driver and an emission driver, and may include a wiring connecting the above drivers. The scan driver transmits scan signals through scan lines to turn on scan thin film transistors included in each of the pixels. The emission driver transmits emission signals through emission lines to turn on emission thin film transistors included in each of the pixels. The embedded circuit unit SE is symmetrically disposed at opposing sides of the display area DA.

[0047] The initialization wiring **112a** is included to overlap the embedded circuit unit SE. Specifically, the initialization wiring **112a** is included to completely overlap the embedded circuit unit SE. The initialization wiring **112a** is a wiring that delivers a voltage for initializing each of the pixels. Initialization operations of the pixels through the initialization voltage will be described in detail later with reference to FIG. 3. The initialization wiring **112a** is included in the same layer as a pixel electrode in order to overlap the embedded circuit unit SE. The embedded circuit unit SE is mainly composed of thin film transistors. Since an insulating layer covering the thin film transistors is included and the initialization wiring **112a** is included on the insulating layer, the embedded circuit unit SE and the initialization wiring **112a** may be formed in different layers and arranged to overlap each other. Since the areas occupied by the embedded circuit unit SE and the initialization wiring **112a** overlap each other in some embodiments, dead space may be reduced and a wider display area DA may be realized within a limited area of the lower substrate **100**. As a result, large-sized screens having a narrow bezel are realized for an OLED display that meet customer needs. Also, according to at least one embodiment, since a portion of the embedded circuit unit SE that is not covered with the connection unit **112b** is covered with the initialization wiring **112a**, the embedded circuit unit SE may be protected from external impact or static electricity.

[0048] FIG. 2 is a circuit diagram illustrating the connections between a pixel and wirings of FIG. 1.

[0049] A pixel circuit PC is connected to the scan driver and the emission driver of the embedded circuit unit SE to receive scan signals $S[n]$ and $S[n-1]$ and an emission signal $EM[n]$. Also, the pixel circuit PC is connected to the initialization wiring **112a** to receive an initialization voltage V_{init} . In addition, the pixel circuit PC receives a data voltage V_{data} from a data wiring and receives first power or driving voltage EL_{vdd} from a first power wiring in order to drive an OLED. One end of the OLED is connected to the pixel circuit PC and the other end of the OLED is connected to the above-described power wiring **106c** to receive a low potential voltage, for example, a second power or common voltage EL_{vss} . Herein, the first power EL_{vdd} may be a positive voltage and the second power EL_{vss} may be a ground (GND) voltage or a negative voltage.

[0050] FIG. 3 is a circuit diagram illustrating region "III" of FIG. 2 in more detail. FIG. 3 illustrates the region "III" of the pixel circuit PC to describe the functionality of the initialization voltage V_{init} . Only six thin film transistors are illustrated in FIG. 3. However, in addition thereto, the pixel circuit PC may further include additional thin film transistors and at least one or more capacitors. In FIG. 3, only the

minimum number of thin film transistors required for describing the functionality of the initialization voltage V_{init} is illustrated. However, the pixel circuit PC is not limited thereto and the pixel circuit PC may be realized in various forms.

[0051] In a first thin film transistor **T1**, a gate electrode is connected to a line supplying the n th scan signal $S[n]$, a first electrode is connected to a wiring supplying the data voltage V_{data} , and a second electrode is connected to a first node **N1**. In a second transistor **T2**, a gate electrode is connected to a third thin film transistor **T3** and first and second electrodes are respectively connected to the first node **N1** and a third node **N3**. In the third transistor **T3**, a gate electrode is connected to a line supplying the $n-1$ th scan signal $S[n-1]$, a first electrode is connected to the initialization wiring **112a**, and a second electrode is connected to a second node **N2**. In a fourth thin film transistor **T4**, a gate electrode is connected to the line supplying the n th scan signal $S[n]$, a first electrode is connected to the third node **N3**, and a second electrode is connected to the second node **N2**. In a fifth thin film transistor **T5**, a gate electrode is connected to a line supplying the n th emission signal $EM[n]$, a first electrode is connected to a wiring supplying the first power EL_{vdd} , and a second electrode is connected to the first node **N1**. In a sixth thin film transistor **T6**, a gate electrode is connected to the line supplying the n th emission signal $EM[n]$, a first electrode is connected to the third node **N3**, and a second electrode is connected to the OLED.

[0052] As a brief description of the driving method, the initialization voltage V_{init} is applied to the second node **N2** when the $n-1$ th scan signal $S[n-1]$ is applied to turn on the third thin film transistor **T3**. Since the initialization voltage V_{init} is a negative voltage, i.e., a low potential voltage, the second node **N2** may have a low potential. For example, the initialization voltage V_{init} may be in the range of about -1 V to about -4 V.

[0053] Next, when the n th scan signal $S[n]$ is applied to turn on the first thin film transistor **T1** and the fourth thin film transistor **T4**, the data voltage V_{data} is applied to the second thin film transistor **T2**. The data voltage is a positive voltage and has a higher potential voltage than at least the initialization voltage V_{init} . For example, the data voltage V_{data} may be in the range of about 2 V to about 7 V. As a result, the second thin film transistor **T2** is subjected to diode connection and may compensate for the threshold voltage variation of the second thin film transistor **T2**.

[0054] Thus, since the initialization voltage V_{init} has a lower potential than the data voltage V_{data} , the initialization voltage V_{init} may compensate for the threshold voltage variation of the driving thin film transistor **T2**. The initialization voltage V_{init} may thus allow the OLED display to display a substantially uniform image. If the initialization voltage V_{init} is absent, the second node **N2** has a floating voltage level and may have a higher potential than the data voltage V_{data} . In this case, since the threshold voltage compensation is not necessarily normally performed, the OLED display may not display a uniform image. According to some embodiments, the position and potential of initialization wiring **112a** delivering the initialization voltage V_{init} that initializes the pixel is different from that of the first power wiring delivering the first power EL_{vdd} and the power wiring **106c** delivering the second power EL_{vss} .

[0055] FIG. 4 is a cross-sectional view taken along line IV-IV' of FIG. 1. FIGS. 5 to 8 are cross-sectional views

sequentially illustrating a method of manufacturing the lower substrate **100** of FIG. 4. Hereinafter, a method of manufacturing an OLED display according to an embodiment will be described in detail with reference to FIG. 4 and FIGS. 5 to 8.

[0056] First, a substrate **10** is prepared. The substrate **10** supports the entire lower substrate **100** by providing a solid foundation. The substrate **10** can be formed of a transparent insulating material having a flat top surface. For example, the substrate **10** may be formed of glass. However, the described technology is not limited thereto. For example, the substrate **10** may be formed of a plastic material such as polyethersulfone (PES) or polyacrylate (PAR). Also, the substrate **10** may be formed of an opaque material such as metal or carbon fibers, or may be formed of a flexible plastic material, such as a polyimide (PI) film, in order to realize a flexible display apparatus.

[0057] The substrate **10** is divided into a display area DA and a non-display area NDA surrounding the display area DA. The non-display area NDA is divided into sections or areas including a sealing unit or sealing area CS, a power wiring unit or power wiring area VS, and an embedded circuit unit or embedded circuit SE is sequentially arranged from the outer non-display area NDA, including the cutting line CL, to the inner non-display area NDA adjacent to the display area DA.

[0058] A buffer layer **101** planarizes the top surface of the substrate **10** and blocks the penetration of impurities into underlying layers. The buffer layer **101** may be formed as a single layer or multiple layers including a layer that is formed of an inorganic material such as silicon oxide (SiO₂) and/or silicon nitride (SiN_x), and the buffer layer **101** may be formed by various deposition methods. The buffer layer **101** may be omitted if necessary.

[0059] Pixel circuits are formed in the display area DA on the buffer layer **101**. Simultaneously, a scan driver and an emission driver are formed in the embedded circuit unit SE of the non-display area NDA on the buffer layer **101**. The pixel circuit includes at least one thin film transistor. The scan driver and the emission driver also include at least one thin film transistor. Although not illustrated in FIG. 4, the pixel circuit, the scan driver, and the emission driver may further include at least one capacitor.

[0060] Although FIG. 4 illustrates a top-gate type thin film transistor (TFT) sequentially including an active layer **102**, a gate electrode **104**, and source/drain electrodes **106a** and **106b**, the described technology is not limited thereto, and various types of TFTs, such as a bottom-gate type, may be used. Hereinafter, the structure of a single TFT included in the pixel circuit will be described as an example. Since the structures of the other TFTs included in the pixel circuit and the TFTs included in the scan and emission drivers are substantially the same, duplicate descriptions thereof are omitted.

[0061] The active layer **102** is formed on the buffer layer **101**. The active layer **102** includes a semiconductor material and for example, may include amorphous silicon or polycrystalline silicon. However, the described technology is not limited thereto. The active layer **102**, may include an oxide semiconductor material such as (In₂O₃)_a(Ga₂O₃)_b(ZnO)_c (I-G-Z—O) (where a, b, and c are real numbers respectively satisfying the conditions of a≥0, b≥0, and c>0). In addition to the I-G-Z—O, the active layer **102** may include an oxide of a material from Groups 12, 13, and 14 metallic elements,

such as zinc (Zn), indium (In), gallium (Ga), tin (Sn), cadmium (Cd), germanium (Ge), or hafnium (Hf), or a combination thereof. The active layer **102** includes a source region and a drain region, which are respectively in contact with the source electrode **106a** and the drain electrode **106b** and a channel region disposed therebetween. When the active layer **102** includes amorphous silicon or polycrystalline silicon, the source region and the drain region may be doped with impurities if necessary.

[0062] A gate insulating layer **103** is formed on the active layer **102** and may be formed as a single layer or multiple layers including a layer that is formed of an inorganic material such as silicon oxide and/or silicon nitride. The gate insulating layer **103** may insulate the active layer **102** and the gate electrode **104**.

[0063] The gate electrode **104** is formed on the gate insulating layer **103**. The gate electrode **104** is connected to a gate line (not shown) applying on/off signals to the TFT. The gate electrode **104** may be formed of a low-resistance metallic material, and for example, may be formed as a single layer or multiple layers including a layer that is formed of a conductive material including molybdenum (Mo), aluminum (Al), copper (Cu), or titanium (Ti).

[0064] An interlayer dielectric **105** is formed on the gate electrode **104**. The interlayer dielectric **105** may insulate the gate electrode **104**, the source electrode **106a**, and the drain electrode **106b**. The interlayer dielectric **105** may be formed as a single layer or multiple layers including a layer that is formed of an inorganic material. For example, the inorganic material may be metal oxide or metal nitride, and specifically, the inorganic material may include silicon oxide (SiO₂), silicon nitride (SiN_x), silicon oxynitride (SiON), aluminum oxide (Al₂O₃), titanium oxide (TiO₂), tantalum oxide (Ta₂O₅), hafnium oxide (HfO₂), or zirconium oxide (ZrO₂).

[0065] The source electrode **106a** and the drain electrode **106b** are formed on the interlayer dielectric **105**. For example, the source electrode **106a** and the drain electrode **106b** may be formed as a single layer or multiple layers including a layer that is formed of a conductive material including Mo, Al, Cu, or Ti. The source electrode **106a** and the drain electrode **106b** are respectively in contact with the source region and the drain region of the active layer **102** through contact holes formed in the interlayer dielectric **105** and the gate insulating layer **103**.

[0066] A power wiring line **106c** is formed in the power wiring unit VS of the non-display area NDA. The power wiring **106c** may be formed of the same material and on the same layer as the source electrode **106a** and the drain electrode **106b** of the TFT. The power wiring **106c** delivers second power, i.e., a low potential voltage, to the counter electrode **115** of an OLED. The power wiring **106c** may be formed of a low resistance metal to reduce wiring resistance and can be formed to have a large width so as to reduce the voltage drop.

[0067] The TFT of the pixel circuit disposed in the display area DA, as illustrated in FIG. 4, and corresponds to the sixth thin film transistor T6 of FIG. 3, wherein one of the source and drain electrodes **106a** and **106b** is in contact with the OLED.

[0068] Next, an insulating layer **107** is formed to cover the TFTs and the power wiring **106c**. In some embodiments, the insulating layer **107** includes a protective layer **107a** covering the entire display area DA and non-display area NDA

and a planarization layer **107b** formed over the protective layer **107a** and covering the display area DA and the embedded circuit unit SE of the non-display area NDA. The protective layer **107a** may protect wirings and circuits disposed thereunder. The planarization layer **107b** may eliminate a difference in height due to the structure of the TFTs and may planarize the top surface of the protective layer **107a**. Thus, the planarization layer **107b** may prevent the occurrence of defects in the OLED due to unevenness of the components formed under the planarization layer **107b**. The protective layer **107a** and the planarization layer **107b** may be formed as a single layer or multiple layers including a layer that is formed of an inorganic material and/or an organic material. For example, the inorganic material may be metal oxide or metal nitride, and specifically, the inorganic material may include SiO_2 , SiN_x , SiON , Al_2O_3 , TiO_2 , Ta_2O_5 , HfO_2 , or ZrO_2 . The organic material may include a general-purpose polymer, such as polymethylmethacrylate (PMMA) or polystyrene (PS), a phenol group-containing polymer derivative, an acrylic polymer, an imide-based polymer, an arylether-based polymer, an amide-based polymer, a fluorinated polymer, a p-xylene-based polymer, a vinylalcohol-based polymer, or a blend thereof. Also, the protective layer **107a** and the planarization layer **107b** may be formed as a composite stack of an inorganic insulating layer and an organic insulating layer.

[0069] Next, an initialization wiring **112a** and the OLED are formed on the planarization layer **107b**.

[0070] Specifically, the OLED includes a pixel electrode **111**, the counter electrode **115** opposite thereto, and an intermediate layer **113** disposed between the two electrodes. A display apparatus may be classified as a bottom emission type, a top emission type, or a dual emission type, based on the emission direction of the OLED. When the pixel electrode **111** is a light-transmitting electrode and the counter electrode **115** is a reflective electrode the display apparatus is a bottom emission type. In the top emission type, the pixel electrode **111** is a reflective electrode and the counter electrode **115** is a transmissive electrode. In the dual emission type, both the pixel electrode **111** and the counter electrode **115** are light-transmitting electrodes.

[0071] The pixel electrode **111** may be patterned to form an island corresponding to each pixel. Also, the pixel electrode **111** contacts the TFT, included in the pixel circuit, through a hole defined in the insulating layer **107**. When the pixel electrode **111** is an anode, the pixel electrode **111** may include at least one or more layers such including transparent conductive oxides with a high work function, such as indium tin oxide (ITO), indium zinc oxide (IZO), zinc oxide (ZnO), indium oxide (In_2O_3), indium gallium oxide (IGO), and aluminum zinc oxide (AZO).

[0072] Since the initialization wiring **112a** is formed of the same material and on the same layer as the pixel electrode **111**, the initialization wiring **112a** may be formed on the planarization layer **107b** and may include the above-described transparent conductive oxide. The initialization wiring **112a** is formed to completely overlap the embedded circuit unit SE. Since the initialization wiring **112a** is connected to a TFT in the display area DA, the initialization wiring **112a** may be formed adjacent to the display area DA in the embedded circuit unit SE. Although not illustrated in FIG. 4, the initialization wiring **112a** contacts the first electrode of the TFT corresponding to the third thin film transistor T3 of FIG. 3 in the display area DA.

[0073] A connection unit **112b** for connecting the power wiring **106c** to the counter electrode **115** of the OLED is further disposed on the planarization layer **107b**. Since the connection unit **112b** connects the power wiring **106c** to the counter electrode **115** of the display area DA, the connection unit **112b** may be formed in the embedded circuit unit SE adjacent to the power wiring unit VS. Since the power wiring **106c** is formed under the protective layer **107a**, an opening exposing a portion of the power wiring **106c** is formed in the protective layer **107a** and the planarization layer **107b**. The connection unit **112b** is formed on the planarization layer **107b** to overlap a portion of the embedded circuit unit SE in order to connect the counter electrode **115** to the power wiring **106c** exposed through the opening. The connection unit **112b** may be formed simultaneously with the pixel electrode **111** and the initialization wiring **112a**, and may include the above-described transparent conductive oxide.

[0074] Next, a pixel-defining layer **109** is formed to cover the embedded circuit unit SE and the display area DA. The pixel-defining layer **109** may be formed of one or more organic insulating materials such as polyimide, polyamide, acrylic resin, benzocyclobutane, or phenol resin by using a method such as spin coating. An opening exposing a portion of the connection unit **112b** is formed in a portion of the pixel-defining layer **109** corresponding to the embedded circuit unit SE. The counter electrode **115** is connected to the connection unit **112b** exposed through the opening. Predetermined openings are formed in portions of the pixel-defining layer **109** corresponding to light-emitting regions of the display area DA. The intermediate layer **113** is formed in at least regions limited to the openings.

[0075] The intermediate layer **113** includes an organic emission layer that emits red, green, or blue light, and a low molecular weight organic material or a polymer organic material may be used to form the organic emission layer. When the organic emission layer is a low molecular weight organic layer formed of the low molecular weight organic material, a hole transport layer (HTL) and a hole injection layer (HIL) may be sequentially formed between the pixel electrode **111** and the organic emission layer, and an electron transport layer (ETL) and an electron injection layer (EIL) may be stacked between the organic emission layer and the counter electrode **115**. Various layers, in addition to the HIL, the HTL, the ETL, and the EIL, may be stacked and formed if necessary.

[0076] In the above-described embodiment, a separate organic emission layer is formed for each pixel. In this embodiment, each pixel may emit red, green, or blue light, and a pixel group that emits red, green, and blue light may constitute a single unit pixel. However, the described technology is not limited thereto. The organic emission layer may be commonly formed over the entire pixel. For example, the plurality of organic emission layers that emit red, green, and blue light may be vertically stacked or mixed to emit white light. However, the combination of colors configured to emit the white light is not limited thereto. In this embodiment, a color conversion layer for converting the emitted white light into a predetermined color or a color filter may be separately included.

[0077] Next, the counter electrode **115** is formed to cover at least the entire display area DA. The counter electrode **115** may be formed of a conductive inorganic material. When the counter electrode **115** functions as a cathode, the counter

electrode **115** may be formed of a material with a low work function, such as lithium (Li), calcium (Ca), LiF/Ca, LiF/Al, Al, magnesium (Mg), or silver (Ag). The counter electrode **115** may be formed as a common electrode over the entire display area DA in which an image is realized. In this embodiment, the counter electrode **115** may be formed by an evaporation process that does not damage the intermediate layer **113**. However, the polarities of the pixel electrode **111** and the counter electrode **115** may be reversed. The counter electrode **115** receives the second power through contact with the connection unit **112b** exposed through the opening.

[0078] Although not illustrated in FIG. 4, an insulating capping layer may be further formed on the counter electrode **115**. The insulating capping layer may maintain the work function of the counter electrode **115** and may prevent damage to the organic material included in the intermediate layer **113**. The encapsulation thin film may be formed by using a sputtering process or a plasma enhanced chemical vapor deposition (PECVD) process.

[0079] When the preparation of the lower substrate **100** is completed, the sealing unit CS surrounding the outer edges of the non-display area NDA is coated with a seal **300** and an upper substrate **200** and the lower substrate **100** are bonded together. Thus, an OLED display is completed.

[0080] FIG. 9 is a cross-sectional view illustrating an OLED display according to another embodiment.

[0081] When compared to the embodiment of FIG. 4, the embodiment of FIG. 9 is different in that an initialization wiring **112a** does not completely overlap, but only partially overlaps the embedded circuit unit SE, and the initialization wiring **112a** is separately composed of an upper layer **1122a** and a lower layer **1121a**. FIGS. 10 to 13 are cross-sectional views sequentially illustrating a method of manufacturing the OLED display of FIG. 9. Hereinafter, a method of manufacturing an OLED display according to another embodiment will be described in detail with reference to FIG. 9 and FIGS. 10 to 13.

[0082] Since processes of preparing a substrate **10** forming an interlayer dielectric **105** are the same as the processes described in the embodiment of FIG. 4, the overlapping description thereof is omitted. Hereinafter, processes of forming a source electrode **106a** and a drain electrode **106b** of a TFT, a power wiring **106c**, and the lower layer **1121a** of the initialization wiring **112a** will be described.

[0083] The source and drain electrodes **106a** and **106b** of the TFT are formed on the interlayer dielectric **105**. For example, the source and drain electrodes **106a** and **106b** may be formed as a single layer or multiple layers including a layer that is formed of a conductive material including Mo, Al, Cu, or Ti.

[0084] A power wiring **106c** is formed on the interlayer dielectric **105** of a power wiring unit VS. Herein, the power wiring **106c** may be formed of the same material and on the same layer as the source and drain electrodes **106a** and **106b** of the TFT. The power wiring **106c** delivers second power or a common voltage, i.e., a low potential voltage, to a counter electrode **115** of an OLED. The power wiring **106c** may be formed of a low resistance metal to reduce wiring resistance and may be formed to have a large width so that a voltage drop may be prevented.

[0085] The lower layer **1121a** of the initialization wiring **112a** is formed on an initialization wiring unit or initialization wiring area VI between the embedded circuit unit SE and the display area DA. In the embodiment of FIG. 9, the

initialization wiring **112a** includes the lower layer **1121a** and the upper layer **1122a** that is in contact with the lower layer **1121a**. Since the lower layer **1121a** may be formed of the same material and on the same layer as the source/drain electrodes **106a** and **106b** and the power wiring **106c**, the initialization wiring **112a** may not completely overlap the embedded circuit unit SE, but may only partially overlap the embedded circuit unit SE. However, since the lower layer **1121a** formed of a low-resistance conductive material including Mo, Al, Cu, or Ti may be included as a part of the initialization wiring **112a**, the wiring resistance may be decreased in comparison to the initialization wiring **112a** formed of only the transparent conductive oxide which is disclosed in the embodiment of FIG. 4.

[0086] Next, the processes of forming a protective layer **107a** and a planarization layer **107b** are the same as those described in the embodiment of FIG. 4, and thus overlapping descriptions thereof are omitted.

[0087] The upper layer **1122a** of the initialization wiring **112a**, a pixel electrode **111** of the OLED, and a connection unit **112b** are formed on the planarization layer **107b**.

[0088] The pixel electrode **111** is formed to contact the TFT, which is included in a pixel circuit, through a hole defined in an insulating layer **107**. When the pixel electrode **111** functions as an anode, the pixel electrode **111** may include at least one or more transparent conductive oxides with a high work function, such as ITO, IZO, ZnO, In₂O₃, IGO, or AZO.

[0089] The connection unit **112b** for connecting the power wiring **106c** to the counter electrode **115** of the OLED is further disposed on the planarization layer **107b**. Since the connection unit **112b** connects the power wiring **106c** to the counter electrode **115** of the display area DA, the connection unit **112b** is formed adjacent to the power wiring unit VS in the embedded circuit unit SE. Since the power wiring **106c** is formed under the protective layer **107a**, an opening exposing a portion of the power wiring **106c** is formed in the protective layer **107a** and the planarization layer **107b**. The connection unit **112b** is formed on the planarization layer **107b** to overlap a portion of the embedded circuit unit SE in order to connect the counter electrode **115** to the power wiring **106c** exposed through the opening. The connection unit **112b** may be formed simultaneously with the pixel electrode **111** and the initialization wiring **112a** and may be formed of the above-described transparent conductive oxide.

[0090] Since the upper layer **1122a** of the initialization wiring **112a** may be formed of the same material and on the same layer as the pixel electrode **111**, the upper layer **1122a** may be formed on the planarization layer **107b** and may be formed of the above-described transparent conductive oxide. The upper layer **1122a** partially overlaps the embedded circuit unit SE and a portion of the upper layer **1122a** is formed on the initialization wiring unit VI. The portion of the upper layer **1122a** formed on the initialization wiring unit VI is in contact with the lower layer **1121a** through a hole of the insulating layer **107**. Although not illustrated in FIG. 9, the upper layer **1122a** or the lower layer **1121a** of the initialization wiring **112a** is connected to the TFT of the display area DA, and for example, may be in contact with the first electrode of the thin film transistor corresponding to the third thin film transistor T3 of FIG. 3 included in the display area DA.

[0091] The lower layer **1121a** of the initialization wiring **112a** completely overlaps the upper layer **1122a** of the

initialization wiring **112a**. Also, the width of the lower layer **1121a** may be less than the width of the upper layer **1122a**. This is to reduce the space occupied by the initialization wiring unit VI in the non-display area NDA, and as a result, the dead space may be reduced.

[0092] According to at least one embodiment, since the initialization wiring **112a** is formed to overlap the embedded circuit unit SE, the area of the non-display area NDA may be reduced in comparison to a comparative example, in which the initialization wiring **112d** occupies a separate space by being formed between an embedded circuit unit SE and a display area DA. With respect to the comparative example of FIG. 14, the initialization wiring **112d** is formed on the same layer as the power wiring and the source and drain electrodes of a TFT. Therefore, the space occupied by the initialization wiring **112d** is relatively wide.

[0093] According to the result of experiments, with respect to the embodiment of FIG. 4, the dead space may be reduced by about 10% in comparison to the comparative example. With respect to the embodiment of FIG. 9, since the initialization wiring **112a** is composed of the upper layer **1122a** and the lower layer **1121a** and the lower layer **1121a** is formed of a low-resistance metallic material, the resistance of the initialization wiring **112a** may be lower than that in the embodiment of FIG. 4.

[0094] According to at least one embodiment, the seal and upper substrate are used when the lower substrate is sealed. However, this is only an exemplary embodiment and a thin film encapsulation structure formed of an organic layer and/or an inorganic layer may be used.

[0095] As described above, according to at least one embodiment, the dead space of a display apparatus may be reduced.

[0096] It should be understood that the exemplary embodiments described herein should be considered in a descriptive sense only and not for purposes of limitation. Descriptions of features or aspects within each embodiment should typically be considered as available for other similar features or aspects in other embodiments.

[0097] While one or more embodiments of the described technology have been described with reference to the figures, it will be understood by those of ordinary skill in the art that various changes in form and details may be made therein without departing from the spirit and scope of the present invention as defined by the following claims.

What is claimed is:

1. An organic light-emitting diode display, comprising:
 - a substrate comprising a display area and a non-display area surrounding the display area;
 - a pixel disposed in the display area, the pixel comprising:
 - a pixel circuit;
 - a first electrode which is electrically connected to the pixel circuit;
 - an intermediate layer disposed on the first electrode and including an organic emission layer; and
 - a second electrode disposed on the intermediate layer;
 - a first wiring disposed in a first area of the non-display area, the first wiring electrically connected to the second electrode to transmit a first signal;
 - a connector disposed in the first area of the non-display area, the connector electrically connecting the first wiring to the second electrode; and
 - a second wiring disposed in the first area of the non-display area and the second wiring electrically con-

nected to the pixel circuit to transmit a second signal which is different from the first signal, wherein the second wiring comprises a first layer, and the first layer is formed of the same material as the connector.

2. The organic light-emitting diode display of claim 1, wherein the second wiring is disposed between the connector and the pixel in a plan-view.

3. The organic light-emitting diode display of claim 2, wherein the second electrode comprises an extended portion which is extended to the non-display area, and the extended portion is contacted to the connector.

4. The organic light-emitting diode display of claim 3, wherein the second wiring is overlapped with the extended portion in a plan-view.

5. The organic light-emitting diode display of claim 4, the display device further comprising a scan driver to transmit a scan signal to the pixel, wherein the connector is overlapped with the scan driver.

6. The organic light-emitting diode display of claim 5, wherein the second signal is an initialization signal which is configured to initialize the pixel.

7. The organic light-emitting diode display of claim 6, wherein the first electrode is formed of the same material as the connector.

8. The organic light-emitting diode display of claim 1, the organic light-emitting diode display further comprising:

- a data line configured to transmit a data signal to the pixel;
- a power line configured to transmit a third signal to the pixel;

- an emission control line configured to transmit an emission control signal to the pixel;

- a first gate line configured to transmit a first scan signal to the pixel; and

- a second gate line configured to transmit a second scan signal to the pixel, wherein the pixel circuit comprises:

- a first switch, the first switch including a control electrode electrically connected to the first gate line, a first terminal electrically connected to the data line, and a second terminal;

- a second switch, the second switch including a control electrode, a first terminal electrically connected to the second terminal of the first switch, and a second terminal electrically connected to the first electrode; and

- a third switch, the third switch including a control electrode electrically connected to the second gate line, a first terminal electrically connected to the second wiring, and second terminal electrically connected to the control electrode of the second switch.

9. The organic light-emitting diode display of claim 8, wherein the pixel circuit further comprises:

- a fourth switch, the fourth switch including a control electrode electrically connected to the first gate line, a first terminal electrically connected to the control terminal of the second switch, and a second terminal electrically connected to the second terminal of the second switch;

- a fifth switch, the fifth switch including a control terminal electrically connected to the emission control line, a first terminal electrically connected to the power line, and a second terminal electrically connected to the first terminal of the second switch;

- a sixth switch, the sixth switch including a control terminal electrically connected to the emission control line, a first terminal electrically connected to the second

- terminal of the second switch, and a second terminal electrically connected to the first electrode; and
 a storage capacitor, the storage capacitor including a first terminal electrically connected to the power line, and a second terminal electrically connected to the control terminal of the second switch.
- 10.** The organic light-emitting diode display of claim **1**, wherein the first layer and the first electrode directly contact a selected surface of the same layer.
- 11.** An organic light-emitting diode display, comprising:
 a substrate comprising a display area and a non-display area surrounding the display area;
 a pixel disposed in the display area, the pixel comprising:
 a pixel circuit;
 a first electrode which is electrically connected to the pixel circuit;
 an intermediate layer disposed on the first electrode and including an organic emission layer; and
 a second electrode disposed on the intermediate layer;
 a first wiring disposed in the non-display area, the first wiring electrically connected to the second electrode to transmit a first signal;
 a connector disposed in the non-display area, the connector electrically connecting the first wiring to the second electrode; and
 a second wiring disposed in the non-display area and the second wiring electrically connected to the pixel circuit to transmit a second signal which is different from the first signal, wherein the second wiring comprises a first layer, and the first layer is formed of the same material as the first electrode.
- 12.** The organic light-emitting diode display of claim **11**, the organic light-emitting diode display further comprising:
 a data line configured to transmit a data signal to the pixel;
 a power line configured to transmit a third signal to the pixel;
 an emission control line configured to transmit an emission control signal to the pixel;
 a first gate line configured to transmit a first scan signal to the pixel; and
 a second gate line configured to transmit a second scan signal to the pixel, wherein the pixel circuit comprises:
 a first switch, the first switch including a control electrode electrically connected to the first gate line, a first terminal electrically connected to the data line, and a second terminal;
 a second switch, the second switch including a control electrode, a first terminal electrically connected to the second terminal of the first switch, and a second terminal electrically connected to the first electrode; and
 a third switch, the third switch including a control electrode electrically connected to the second gate line, a first terminal electrically connected to the second wiring, and second terminal electrically connected to the control electrode of the second switch.
- 13.** The organic light-emitting diode display of claim **12**, wherein the pixel circuit further comprises:
 a fourth switch, the fourth switch including a control electrode electrically connected to the first gate line, a first terminal electrically connected to the control terminal
- of the second switch, and a second terminal electrically connected to the second terminal of the second switch;
 a fifth switch, the fifth switch including a control terminal electrically connected to the emission control line, a first terminal electrically connected to the power line, and a second terminal electrically connected to the first terminal of the second switch;
 a sixth switch, the sixth switch including a control terminal electrically connected to the emission control line, a first terminal electrically connected to the second terminal of the second switch, and a second terminal electrically connected to the first electrode; and
 a storage capacitor, the storage capacitor including a first terminal electrically connected to the power line, and a second terminal electrically connected to the control terminal of the second switch.
- 14.** The organic light-emitting diode display of claim **13**, wherein the first electrode is formed of the same material as the connector.
- 15.** The organic light-emitting diode display of claim **14**, wherein the second wiring is disposed between the connector and the pixel in a plan-view.
- 16.** The organic light-emitting diode display of claim **15**, wherein the second electrode comprises an extended portion which is extended to the non-display area, and the extended portion is contacted to the connector.
- 17.** The organic light-emitting diode display of claim **16**, wherein the second wiring is overlapped with the extended portion in a plan-view.
- 18.** The organic light-emitting diode display of claim **11**, wherein the second wiring further comprises a second layer, the second layer is disposed between the substrate and the first layer, the second layer is electrically connected to the first layer, and the second layer is overlapped with the first electrode.
- 19.** The organic light-emitting diode display of claim **18**, wherein the second layer is formed of the same material as the first wiring.
- 20.** An organic light-emitting diode display, comprising:
 a substrate comprising a display area and a non-display area surrounding the display area;
 a pixel disposed in the display area, the pixel comprising:
 a pixel circuit;
 a first electrode which is electrically connected to the pixel circuit;
 an intermediate layer disposed on the first electrode and including an organic emission layer; and
 a second electrode disposed on the intermediate layer;
 a first wiring disposed in the non-display area, the first wiring electrically connected to the second electrode to transmit a first signal;
 a connector disposed in the non-display area, the connector electrically connecting the first wiring to the second electrode; and
 a second wiring disposed in the non-display area and the second wiring electrically connected to the pixel circuit to transmit a second signal which is different from the first signal, wherein the second wiring comprises a first layer, and the first layer is formed of the same material as the first electrode and the connector.

专利名称(译)	有机发光二极管 (OLED) 显示器及其制造方法		
公开(公告)号	US20190272789A1	公开(公告)日	2019-09-05
申请号	US16/419741	申请日	2019-05-22
[标]申请(专利权)人(译)	三星显示有限公司		
申请(专利权)人(译)	三星DISPLAY CO. , LTD.		
当前申请(专利权)人(译)	三星DISPLAY CO. , LTD.		
[标]发明人	PYON CHANG SOO		
发明人	PYON, CHANG-SOO		
IPC分类号	G09G3/3258 H01L51/52 G09G3/3291 H01L27/32 G09G3/3233 H01L51/56 G09G3/3266		
CPC分类号	G09G3/3258 G09G2310/0264 G09G3/3291 H01L27/3276 G09G3/3233 H01L51/56 H01L27/3279 H01L27/3262 G09G3/3266 H01L27/3258 H01L27/3248 H01L51/5246 G09G2300/0842 G09G2300/0861 G09G2300/0819 H01L2227/323 G09G2300/043 G09G2300/0426 H01L51/5203		
优先权	1020130130452 2013-10-30 KR		
外部链接	Espacenet USPTO		

摘要(译)

公开了一种有机发光二极管 (OLED) 显示器。在一个方面, OLED显示器包括下基板, 该下基板包括显示区域和围绕显示区域的非显示区域, 其中在显示区域中形成多个像素。OLED显示器还包括: 嵌入电路, 被配置为将多个信号施加到像素; 以及初始化布线, 形成在非显示区域中并被配置为将初始化电压施加到每个像素。初始化电路形成在一层中, 以便至少部分地与嵌入电路的区域重叠。

